

# Instruction manual

# Bevel gearbox

Installation – Operation – Maintenance – Inspection

ZK-065 – ZK-140

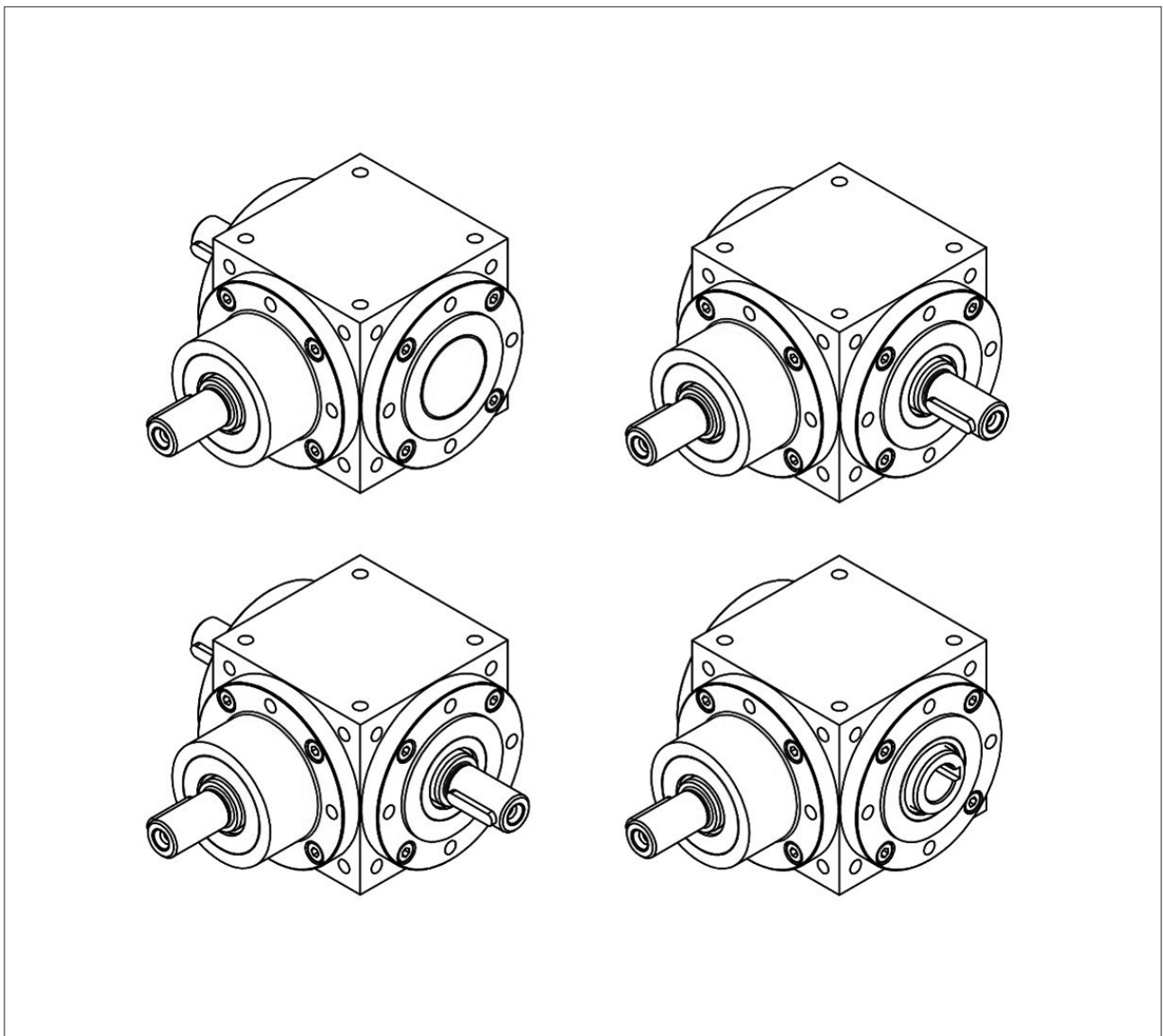

## **Translation of the original**

### **Instruction manual Publisher**

ZIMM GmbH

Millennium Park 3

6890 Lustenau/Austria

Phone: +43 (0) 5577 806-0

Fax: +43 (0) 5577 806-8

E-Mail: [info@zimm.com](mailto:info@zimm.com)

Internet: <https://www.zimm.com>

### **Author**

ZIMM GmbH

### **Date of issue**

2026-03

### **Version**

1.0

### **Copyright**

© ZIMM GmbH

Subject to technical and content changes.

### **Legal information**

The contents of these operating instructions are confidential and intended for operating personnel only.

Reproduction or passing on and transfer of these operating instructions to third parties is prohibited and will result in liability for damages.

ZIMM GmbH accepts no liability for damage caused by non-compliance with these operating instructions.

# Table of contents

<b>1</b>	<b>About this document</b> .....	<b>4</b>
1.1	Handling these operating instructions .....	4
1.2	Symbols and labeling .....	4
<b>2</b>	<b>Security</b> .....	<b>5</b>
2.1	Intended use .....	5
2.2	Obligations of the operator .....	5
<b>3</b>	<b>Scope of supply</b> .....	<b>6</b>
<b>4</b>	<b>Product description</b> .....	<b>6</b>
4.1	Overview .....	6
4.2	Nameplate .....	7
4.3	Versions / Variants .....	7
<b>5</b>	<b>Transportation and storage</b> .....	<b>9</b>
5.1	Transportation .....	9
5.2	Storage .....	10
<b>6</b>	<b>Assembly</b> .....	<b>11</b>
6.1	Installing the breather .....	12
6.2	Installing the oil sight glass .....	13
6.3	Installing the ZIMM ZK bevel gearbox .....	13
6.4	Fitting couplings and connecting shafts .....	14
6.5	Test run .....	16
6.6	Commissioning .....	17
6.7	Run-in phase .....	17
<b>7</b>	<b>Operation and maintenance</b> .....	<b>18</b>
7.1	Inspection .....	18
7.2	Lubrication .....	19
7.3	Troubleshooting .....	23
<b>8</b>	<b>Decommissioning and recommissioning</b> .....	<b>24</b>
<b>9</b>	<b>Repair and replacement</b> .....	<b>24</b>
<b>10</b>	<b>Waste disposal</b> .....	<b>24</b>
<b>11</b>	<b>Declaration of incorporation</b> .....	<b>25</b>
<b>12</b>	<b>Annex: Inspection log</b> .....	<b>26</b>





# 1 About this document

## 1.1 Handling these operating instructions

These operating instructions are part of the ZIMM ZK bevel gearbox.

- Read the operating instructions carefully before use.
- Keep the operating instructions for the entire service life.
- Make the operating instructions accessible to operating and maintenance personnel at all times.
- Pass the operating instructions on to any subsequent owner or user.
- Update the operating instructions with every supplement received from the manufacturer.

## 1.2 Symbols and labeling

Symbol	Meaning
 <b>DANGER</b>	Dangers for persons. Disregard will lead to death or serious injuries.
 <b>WARNING</b>	Dangers for persons. Non-compliance can lead to death or serious injury.
 <b>CAUTION</b>	Dangers for persons. Non-observance can lead to minor injuries.
 <b>CAUTION</b>	Information to prevent damage to property.
 <b>NOTE</b>	Tips for understanding or optimizing work processes.
✓	Prerequisite for an instruction manual.
→	One-step call to action.
1. ... 2. ...	Multi-step instructions. → Observe the sequence.

Tab. 1: Symbols and labeling

## 2 Security

The ZIMM ZK bevel gearbox is built according to the state of the art and recognized safety regulations. Nevertheless, danger to life and limb of the user or third parties or damage to the ZIMM ZK bevel gearbox and other property may occur during use.

- Only use the ZIMM ZK bevel gearbox if it is in perfect technical condition and in accordance with the operating instructions.
- Have any defects rectified without delay.
- Do not make any unauthorized modifications to the ZIMM ZK bevel gearbox.
- Only use original spare parts from ZIMM GmbH.

### 2.1 Intended use

ZIMM ZK bevel gearboxes are generally only intended for the redirection and distribution of rotary movements and may only be operated within the scope described in our catalogs and brochures and within the permissible limit values.

ZIMM ZK bevel gearboxes are not suitable for use in potentially explosive atmospheres.

The user is responsible for the respective application.

Any use beyond this is considered improper use.

In cases of doubt, the use of the ZIMM ZK bevel gearbox must be clarified in advance with ZIMM GmbH.

### 2.2 Obligations of the operator

- Ensure that the ZIMM ZK bevel gearboxes are only operated and maintained in accordance with these operating instructions and the nationally applicable regulations and directives.
- Ensure that the personnel
  - are authorized to operate the ZIMM ZK bevel gearbox,
  - are trained and qualified for the respective activity,
  - have read and understood these operating instructions,
  - know the relevant safety regulations and
  - wear personal protective equipment.

### 3 Scope of supply

The ZIMM ZK bevel gearbox is delivered in sufficiently secured packaging to prevent possible shipping damage.

The following parts are included in the scope of supply of the ZIMM ZK bevel gearbox:

- ZIMM ZK bevel gearbox
- These operating instructions
- Further parts according to delivery note

### 4 Product description

#### 4.1 Overview

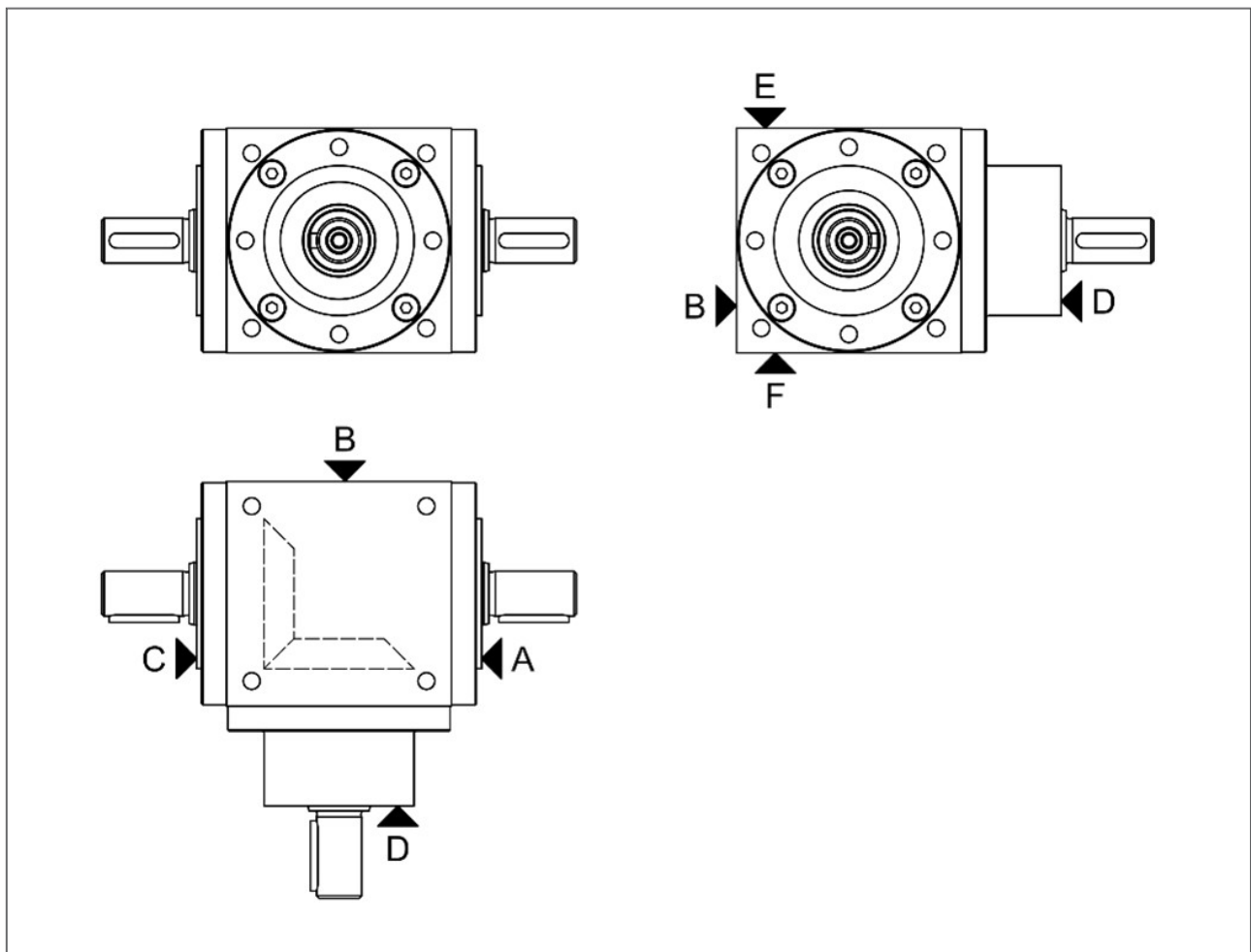

Fig. 1: Overview ZIMM ZK bevel gearbox

A to F: Sides of the ZIMM ZK bevel gearbox. The position of the bevel gears is shown dashed

## 4.2 Nameplate

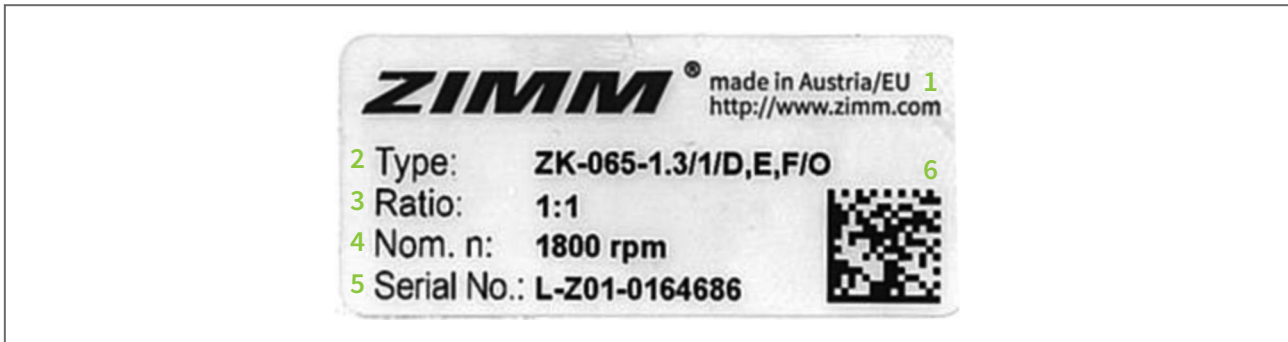

Fig. 2: Example of a nameplate for size ZK-065



Fig. 3: Example of a nameplate from size ZK-090

- |   |                   |   |                                      |
|---|-------------------|---|--------------------------------------|
| 1 | ZIMM contact data | 4 | max. input speed                     |
| 2 | Type designation  | 5 | Serial number                        |
| 3 | Gear ratio        | 6 | Serial number<br>as Data Matrix code |

For gearboxes without oil holes, the nameplate is located on gearbox side B.

For gearboxes with oil holes, the nameplate is located on the side of the oil holes.

The upper nameplate section with the ZIMM logo always points in the direction of the output bevel gear.

## 4.3 Versions / Variants

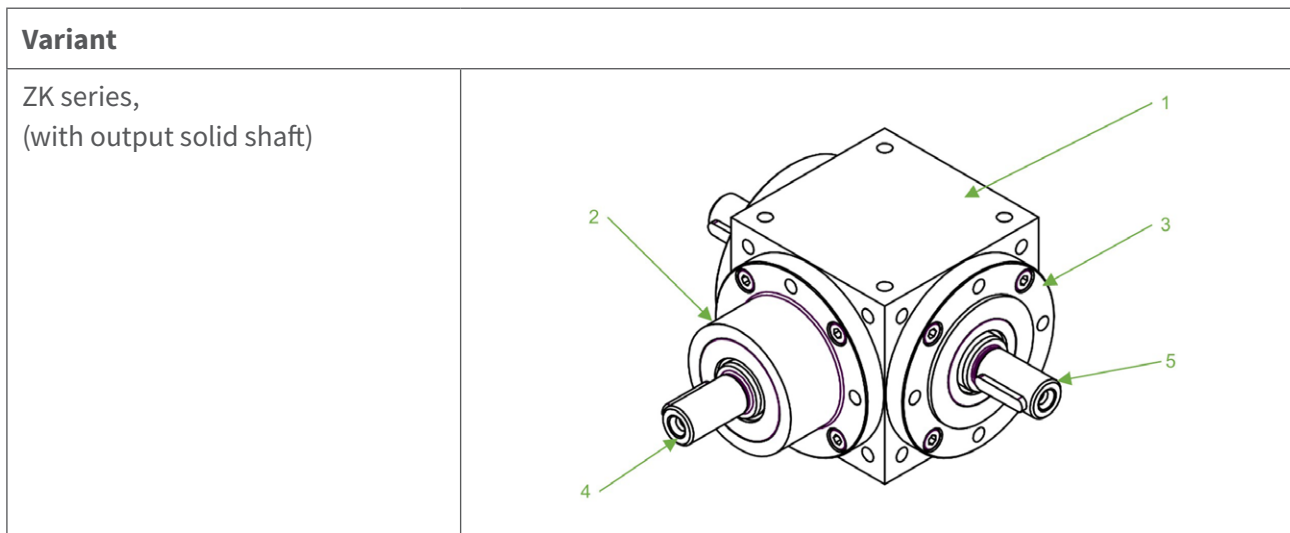

Fig. 4: ZK series with output solid shaft

- |   |                |   |              |
|---|----------------|---|--------------|
| 1 | Housing        | 4 | Drive shaft  |
| 2 | Bearing flange | 5 | Output shaft |
| 3 | Bearing cover  |   |              |

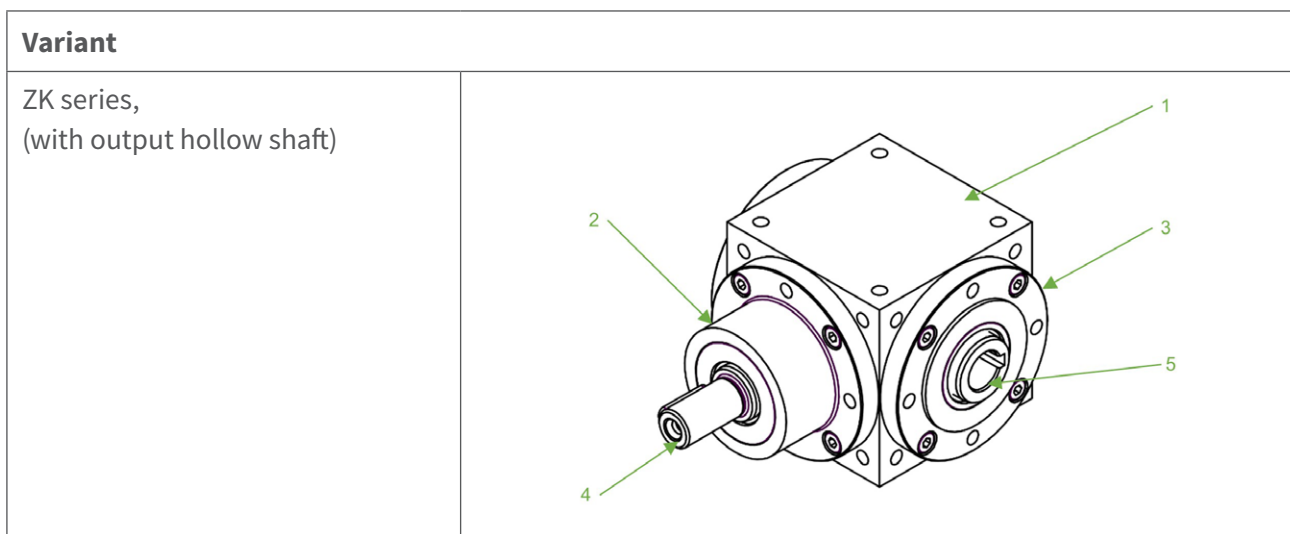

Fig. 5: ZK series with output hollow shaft

- |   |                |   |                     |
|---|----------------|---|---------------------|
| 1 | Housing        | 4 | Drive shaft         |
| 2 | Bearing flange | 5 | Output hollow shaft |
| 3 | Bearing cover  |   |                     |

## 5 Transportation and storage

### 5.1 Transportation



#### WARNING

##### Falling load!

Falling of the load can lead to serious injuries.

- Ensure that the retaining straps used are securely fastened and cannot slip.
- Do not stand under the suspended load.
- Wear personal protective equipment.



#### CAUTION

##### High weight!

Injuries with components from 25 kg.

- Transport heavy ZIMM ZK bevel gearboxes properly (max. 25 kg per person).



#### CAUTION

##### Damage to the ZIMM ZK bevel gearbox!

- Check the packaging for damage upon receipt.
- Do not drop the ZIMM ZK bevel gearbox and do not expose it to shocks.
- Use suitable lifting gear if required.

##### Transport fastening

For safe suspension, eyebolts can be attached to the mounting holes in the gearbox housing (not included in the scope of supply).



### CAUTION

#### **Incorrect storage!**

Damage due to corrosion.

- Store only in enclosed and dry rooms.
- Protected against ground moisture.
- Store only briefly in covered outdoor areas.
- Carry out commissioning no later than 1 year after delivery (the delivery date from ZIMM is decisive).

→ For other storage conditions and storage times: consult ZIMM GmbH.



### WARNING

#### **Risk of shearing, trapping and crushing!**

- Switch off the complete system and secure it against being switched on again.
- Only have work carried out by trained specialist personnel.
- Do not remove existing covers.
- Wear personal protective equipment.



### CAUTION

#### **Strong application of force!**

Damage to the complete system and ZIMM ZK bevel gearbox.

- Ensure that the following assembly conditions are complied with:
  - Tolerance of parallelism and angularity to suit the permissible assembly errors of the connecting elements used.
  - The direction of rotation and movement of all components is correct.



### NOTE

Additional hazards may exist during installation and operation of the complete system.

- Observe regional regulations and carry out the required measures (e.g. risk assessment).
- Document all additional hazards in the documentation of the complete system.

## 6.1 Installing the breather

- ✓ If required / on request, the ZIMM ZK bevel gearbox is equipped with oil holes and a breather is supplied.
  - ✓ The breather must always be mounted on the uppermost oil hole.
  - ✓ The ZIMM ZK bevel gearboxes can be used in different mounting positions. Customer-side installation of the breather ensures that the breather is used in the correct position.
  - ✓ The breather can only be installed after final installation of the ZIMM ZK bevel gearbox, as otherwise oil may leak during transport.
1. Position the ZIMM ZK bevel gearbox according to the intended mounting position.
  2. Loosen the sealing screw (pos. 1) where the breather is to be inserted.
  3. Mount the elbow on the housing. The elbow opening must point upwards. The use of liquid sealant is recommended.
  4. Fasten the breather valve to the elbow. The use of liquid sealant is recommended.

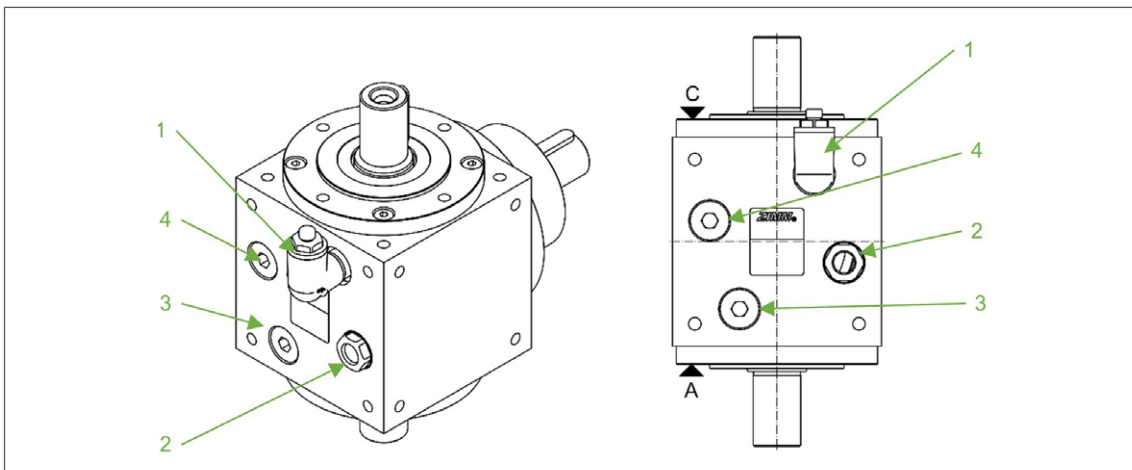

Fig. 6: Example position of breather and oil sight glass

- |   |                            |   |                          |
|---|----------------------------|---|--------------------------|
| 1 | Elbow with breather        | 3 | Drain screw              |
| 2 | Oil sight glass (optional) | 4 | Additional sealing screw |

## 6.2 Installing the oil sight glass

### CAUTION

#### **Leakage of lubricants possible!**

- Avoid eye contact!
  - Wear personal protective equipment
- Ensure that lubricant cannot enter the environment.
  - Use a suitable base

- ✓ If required / on request, the ZIMM ZK bevel gearbox is equipped with oil holes.
- ✓ From size ZK-140, an oil sight glass is also supplied with gearboxes with oil holes.
- ✓ The ZIMM ZK bevel gearboxes can be used in different mounting positions. Customer-side installation of the oil sight glass ensures that the oil sight glass is used in the correct position.
- ✓ In addition, transport damage is avoided by on-site installation.
- 1. Position the ZIMM ZK bevel gearbox so that the oil holes point upwards.
- 2. Loosen the sealing screw located at the position “Oil sight glass” (Fig. 6).
- 3. Install the oil sight glass. The use of liquid sealant is recommended.

## 6.3 Installing the ZIMM ZK bevel gearbox

- ✓ The required installation accuracies result from the permissible assembly tolerances of the connecting elements used.
- ✓ The permissible lateral forces on the input and output shaft of the ZIMM ZK bevel gearbox must not be exceeded.
- ✓ The ZIMM ZK bevel gearbox must be installed without the use of force, in particular no blows may be applied to the input and output shafts.
- 1. Set up the ZIMM ZK bevel gearbox and ensure compliance with the installation accuracies (e.g. with a precision machine spirit level).
- 2. Install the ZIMM ZK bevel gearbox with screws, tighten the assembly screws (not included in the scope of supply).

The direction of rotation of the output shafts can be changed in design 1.3 (T version) by turning the ZIMM ZK bevel gearbox through 180°

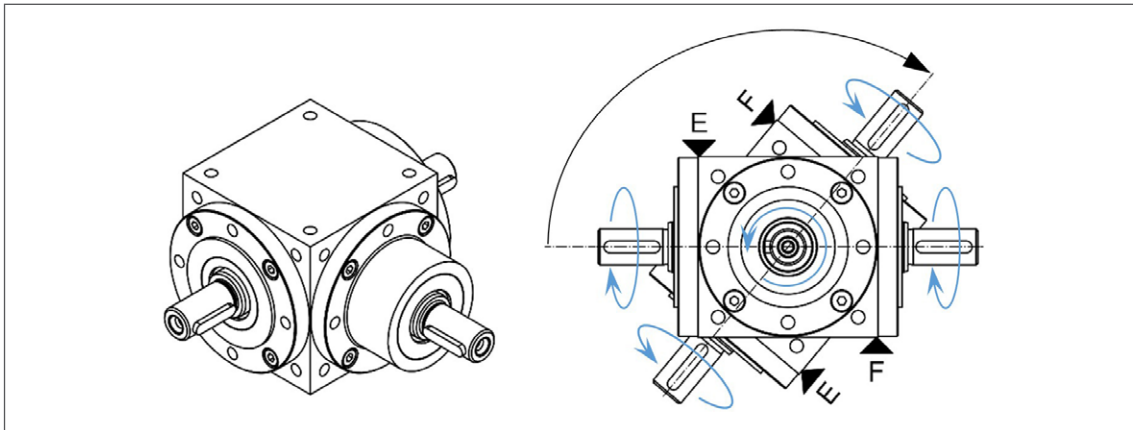

Fig. 7: Change in direction of rotation for design 1.3

- ✓ When installing, ensure the correct direction of rotation.
- ✓ Check that breather / oil sight glass are in the correct positions.

## 6.4 Fitting couplings and connecting shafts

- ✓ The ZIMM ZK bevel gearboxes to be connected are installed.

### CAUTION

#### **Moving parts!**

Injuries due to rotating parts.

→ Switch off the complete system and secure it against being switched on again.

1. Place the connecting shaft onto the shaft journals of the ZIMM ZK bevel gearboxes. Ensure correct leveling of the gearboxes.
2. Fix coupling half-shells with assembly screws using the following tightening torques:

Connecting shaft	Coupling	Tightening torque
VWZ-30	KUZ-KK-16	4 Nm
VWZ-40	KUZ-KK-24	8 Nm
VWZ-60	KUZ-KK-32	15 Nm
VWZ-60V	KUZ-KK-35	35 Nm
VWZ-80	KUZ-KK-45	70 Nm
VWZ-100	KUZ-KK-60	120 Nm

Tab. 2: Screw tightening torques for VWZ and KUZ-KK



## CAUTION

### Axial joining force!

Damage to rolling bearings, retaining rings etc.

- Pull on parts to be mounted using a suitable device.
- Avoid blows or impacts on shaft journals.

3. Pull KUZ couplings (couplings without half-shells) onto the shaft journals.  
Fix grub screw with the following tightening torques:

Size KUZ-..	Grub screw	Tightening torque
09, (14)	M4	1,5 Nm
24, 28	M5	2,0 Nm
14, 19, 38	M6	4,8 Nm
45, 55, 60	M8	10 Nm
70, 75, 90	M10	17 Nm

Tab. 3: Grub screw tightening torques for KUZ

To increase safety, the grub screw can be secured with “medium-strength” threadlocker.

## 6.5 Test run

- ✓ System installed and aligned.

### CAUTION

#### **Lateral forces due to incorrect alignment!**

Damage to gearbox.

1. In case of incorrect alignment:
2. Repeat the test run.

#### **Strong application of force!**

Damage to the ZIMM ZK bevel gearbox.

- Ensure that the directions of rotation of the individual shafts are correct.
- Ensure that add-on parts do not collide with other components.

### NOTE

- Ensure that the mechanics being actuated can move throughout the entire process.

- Run through one cycle.  
Observe the following:
  - Run slowly and carefully.
  - Run with no load or only a low load if possible.
  - The torques and lateral forces approved for the ZIMM ZK bevel gearbox must not be exceeded.
  - Current / torque consumption within the normal range and constant.  
Strong fluctuations indicate alignment errors and stresses.
  - Monitor temperature and avoid overheating.

## 6.6 Commissioning

- ✓ ZIMM ZK bevel gearbox and add-on parts installed and connected.
- ✓ Test run completed successfully.



### CAUTION

#### **Strong application of force!**

Damage to the ZIMM ZK bevel gearbox.

- Ensure that the directions of rotation of the individual shafts are correct.
- Ensure that add-on parts do not collide with other components.



### NOTE

- Ensure that the mechanics being actuated can move throughout the entire process.

1. Check all screw connections again.
2. Carry out a test run with operating torque.  
Pay attention to the following:
  - No unexpected torque peaks occur.
  - Current consumption is constant.
  - Operating temperature is within the normal range.

## 6.7 Run-in phase

The run-in phase of the ZIMM ZK bevel gearbox usually lasts between 40 and 80 operating hours. During this time, a higher torque and a higher operating temperature must be expected.

## 7 Operation and maintenance



### WARNING

#### Rotary movement in the danger zone!

Serious injury or death.

→ Leave the danger zone and secure it.



### CAUTION

#### Hearing damage possible!

Depending on the installation situation and load, sound pressure levels of over 85 dB(A) can be reached.

→ Wear hearing protection.



### CAUTION

#### Risk of burns!

High operating temperature.

→ Allow the ZIMM ZK bevel gearbox to cool down.

## 7.1 Inspection

ZIMM ZK bevel gearboxes must be inspected regularly to ensure trouble-free operation:

- First inspection after 1 month at the latest.
  - Further inspections at least once a year.
  - The inspection intervals must be adapted to the operating conditions or external influences.
1. Record inspections, for template see “Annex: Inspection log”, page 26.
  2. If necessary, carry out troubleshooting, see chapter 7.3, page 23.
- If problems cannot be localized and rectified:  
Contact ZIMM GmbH.

## 7.1.1 Visual inspection

- ✓ Machine switched off and secured against being switched on again.
- 1. Check the ZIMM ZK bevel gearbox for damage.
- 2. Check the screws for fastenings and couplings / connecting shafts and tighten if necessary.
- 3. Check the clutch spiders visually.
- 4. Check coatings and surface coatings: repair any existing coating and paint damage or renew the surface protection.
- 5. Run machine, paying attention to the following:
  - Smooth and vibration-free operation
  - No excessive noise development
  - Consistent power consumption
  - Temperature rise within the permissible range

## 7.2 Lubrication

Good lubrication and the right lubricant are decisive for the function and service life of the ZIMM ZK bevel gearbox.

Each application of ZIMM ZK bevel gearboxes has different requirements, therefore the following chapters contain only recommendations.

Gearboxes of the ZIMM ZK bevel gearboxes are sealed and filled with high-quality oil.

Under normal conditions, the gearbox is lubricated for life.

For increased loads, we recommend:

- First lubricant change after 500 operating hours
- Further lubricant changes every 6000 operating hours

For lower duty cycle, the lubricant should be replaced every 5 years.

### NOTE

The ZIMM ZK bevel gearbox is supplied ex works with initial lubrication.



### Lubricants

Standard lubricant for all sizes: Mobilgear 600 XP

## 7.2.1 ZIMM ZK bevel gearbox lubricant change

### CAUTION

#### **Leakage of lubricants possible!**

- Avoid eye contact!
  - Wear personal protective equipment
- Ensure that lubricant cannot enter the environment.
  - Use a suitable base

### CAUTION

#### **Risk of burns!**

- High operating temperature.
- Allow the ZIMM ZK bevel gearbox to cool down.

### CAUTION

#### **Unsuitable lubricant!**

- Damage to the bearings.
- Damage to the gearing.
- Do not use multi-purpose greases.
  - Do not mix greases.
  - Use special grease if required.
  - Only use lubricants approved by ZIMM GmbH.
  - ZIMM will be happy to advise you.

### NOTE

Due to production reasons, lubricant quantities during initial filling at ZIMM and during lubricant changes may differ.

**! NOTE**

There are also different lubricants for different applications.

- High temperature
- Low temperature
- Food industry
- etc.

→ ZIMM will be happy to advise you

Size	ZK-065	ZK-090	ZK-120	ZK-140
Lubricant quantity (ml)	55	130	340	600

Tab. 4: Lubricant quantities

**a) Lubricant change for ZIMM ZK bevel gearbox WITH oil holes**

1. Warm up the ZIMM ZK bevel gearbox to approx. 40°C.
2. Place a suitable container underneath to catch the lubricant.
3. Open drain screw pos. 3 (see Fig. 6, chapter 6.1).
4. For better air supply, the additional sealing screw pos. 4 (see Fig. 6, chapter 6.1) can also be opened.
5. Close the drain screw after complete emptying.
6. Fill the ZIMM ZK bevel gearbox with suitable lubricant. Quantity according to lubricant quantity table.
7. If an oil sight glass is present, the oil level must reach the upper edge of the oil sight glass.

**b) Lubricant change for ZIMM ZK bevel gearbox WITHOUT oil holes**

1. Warm up the ZIMM ZK bevel gearbox to approx. 40°C.
2. Place a suitable container underneath to catch the lubricant.
3. Position the ZIMM ZK bevel gearbox so that the bearing flange with the drive shaft points upwards.
4. Loosen the screw connection of the bearing flange.
5. Mark the position of the drive shaft and output shaft relative to each other so that during reassembly the same tooth pairing engages again.
6. Remove the bearing flange including the drive shaft.
7. Turn the ZIMM ZK bevel gearbox by 180° and empty it completely.

8. Reposition the bearing flange opening upwards.
9. Fill the ZIMM ZK bevel gearbox with suitable lubricant. Quantity according to the lubricant quantity table.
10. The lubricant level should settle at approximately the axis height of the output shaft.
11. Insert the bearing flange carefully. Ensure that the markings made in point 5 match.
12. Tighten the screw connection of the bearing flange again.

Gearbox size	Screw standard	Screw	Tightening torque
ZK-065	DIN 912	M4	3 Nm
ZK-090	DIN 912	M6	8,8 Nm
ZK-120	DIN 912	M8	24,9 Nm
ZK-140	DIN 912	M8	24,9 Nm

Tab. 5: Screw tightening torques for housing-bearing flange connection

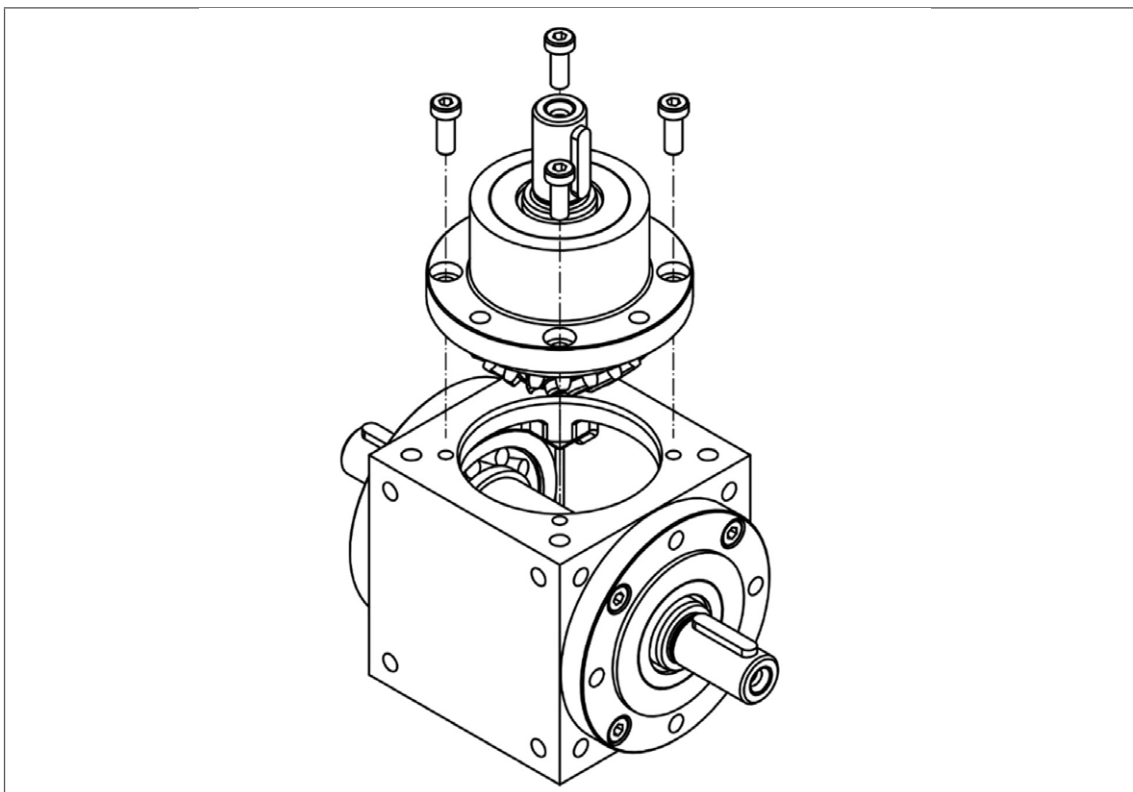

Fig. 8: Installation/removal bearing flange

## 7.3 Troubleshooting

If faults are recognizable, they can be isolated according to certain criteria and remedied with the corresponding measures.

The following table is intended to help find approaches for troubleshooting.

<b>Fault</b>	<b>Possible cause</b>	<b>Measure</b>
Temperature too high	Too high operating Load or duty cycle	→ Check operating parameters, ZIMM will be happy to advise you.
	Geometry error in the system	→ Check alignment: <ul style="list-style-type: none"> <li>• Parallelism of the ZIMM ZK bevel gearboxes with each other</li> <li>• Angularity of the screw-on surfaces</li> </ul>
Noise at coupling or connecting shaft	Friction in the coupling star	→ Lubricate the coupling star with Vaseline or plastic-compatible grease.
	Permissible offset exceeded	→ Check and correct alignment.
Slight leakage at the shaft seal	Slight leakage	Slight leakage is normal and not a technical problem. → Wipe off leakage and continue monitoring.
Gross leakage	Shaft sealing ring defective or excessive pressure in the gearbox	→ Contact ZIMM and send photos.
Suddenly increased noise / vibrations	Wear damage on gearing or bearing arrangement	→ Contact ZIMM, if possible send a video recording with audio.

## 8 Decommissioning and recommissioning

### Decommissioning

#### CAUTION

##### **Corrosion!**

Damage to the ZIMM ZK bevel gearbox during prolonged standstill.

→ Oil bare spots.

### Recommissioning

After a prolonged standstill of the ZIMM ZK bevel gearbox, run through the full cycle with a low load so that bearings and gearing are wetted again with a lubricating film.

## 9 Repair and replacement

#### NOTE

Warranty is void if the ZIMM ZK bevel gearbox is disassembled.

→ Only have the ZIMM ZK bevel gearbox disassembled by ZIMM or by personnel authorized by ZIMM.

→ Get in touch with ZIMM GmbH.

## 10 Waste disposal

The ZIMM ZK bevel gearbox complies with the current standards and guidelines for the disposal of old appliances and does not contain any toxic substances that require special precautions.

→ During disposal, ensure:

- Compliance with regional laws and regulations on waste disposal
- Professional disposal and recycling by a professional waste disposal company

The following materials are for disposal:

- Lubricants (grease or oil in the gearbox)
- Steel parts (with environmentally friendly paints or coatings)
- Plastic parts (seals etc.)

# 11 Declaration of incorporation

**ZIMM GmbH**  
Millennium Park 3 | 6890 Lustenau | Austria  
T: +43 (0) 5577/806-0 | F: +43 (0) 5577/806-8  
E-Mail: [info@zimm.com](mailto:info@zimm.com) | [www.zimm.com](http://www.zimm.com)



## Declaration of incorporation for partly completed machinery (Described in EC Machinery Directive 2006/42/EC, Annex II B)

The manufacturer "ZIMM GmbH" declares herewith that all "bevel gearboxes" delivered by ZIMM of the model ZK

**Size**  
065  
090  
120  
140

including the attachments described in the ZIMM engineering catalogue valid at the time of delivery

conform with the following essential requirements of the **Machinery Directive 2006/42/EC**:  
Annex I, Article 1.1.2, 1.1.3, 1.1.5, 1.3.2, 1.3.4, 1.5.8, 1.5.9 and 1.5.13

In addition we declare that the relevant technical documentation for this partly completed machinery was prepared in accordance with Annex VII, part B, and undertake to transmit these to the market oversight authorities upon request.  
Authorised representative for the compilation of the relevant technical documentation:  
ZIMM GmbH, AT-6890 Lustenau, Millennium Park 3

**Putting the partly completed machinery into service is prohibited until the partly completed machinery has been incorporated into final machinery which conforms to the provisions of the EC Machinery Directive and there is an EC Declaration of Conformity in accordance with Annex II A.**

**Enclosure: current assembly instructions**

ZIMM GmbH  
Millennium Park 3  
AT-6890 Lustenau, 28th August 2019

Gunther Zimmermann, CEO

A: Raiffeisenlandesbank Bregenz  
Kontonr. 11999 | BLZ 37000  
IBAN: AT40 3700 0000 0001 1999  
BIC: RLVGAT2B

CH: BTV Staad  
IBAN CHF: CH38 0852 5000 SA31 733A A  
IBAN EUR: CH11 0852 5000 SA31 733A B  
BIC: BTVACH22

FN 61869 i | Feldkirch  
ATU 69063247  
ARA-Lizenznr. 4334

ZIMM GmbH  
Millennium Park 3 | [info@zimm.com](mailto:info@zimm.com)  
A-6890 Lustenau | +43(0)5577 806-0



